

# PRIMEI ACCESORIOS CARPINTERIA

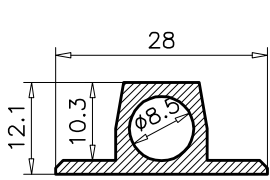

**1.334**  
 PESO TCO: 0.300  
 PERIMETRO: 0.10

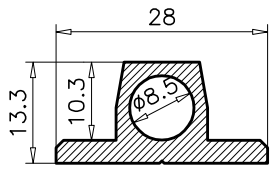

**3.314**  
 PESO TCO: 0.392  
 PERIMETRO: 0.11

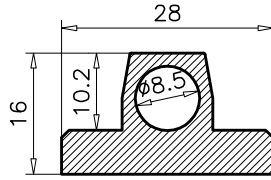

**2.086**  
 PESO TCO: 0.594  
 PERIMETRO: 0.11

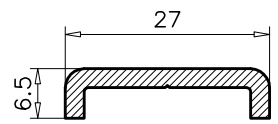

**3.317**  
 PESO TCO: 0.230  
 PERIMETRO: 0.10

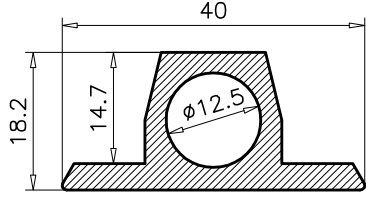

**1.333**  
 PESO TCO: 1.213  
 PERIMETRO: 0.42

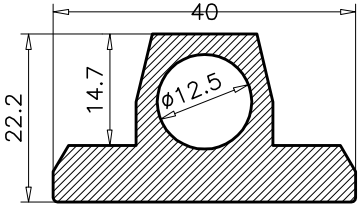

**2.162**  
 PESO TCO: 1.126  
 PERIMETRO: 0.16

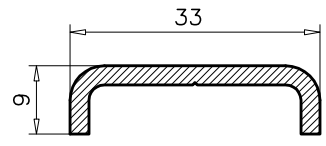

**3.316**  
 PESO TCO: 0.292  
 PERIMETRO: 0.10

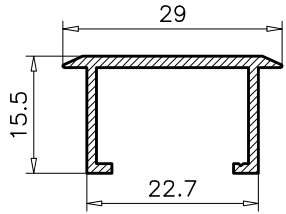

**5.693**  
 PESO TCO: 0.221  
 PERIMETRO: 0.12

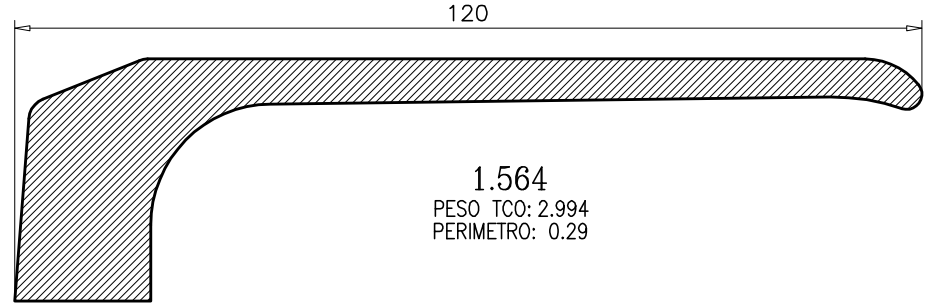

**1.564**  
 PESO TCO: 2.994  
 PERIMETRO: 0.29

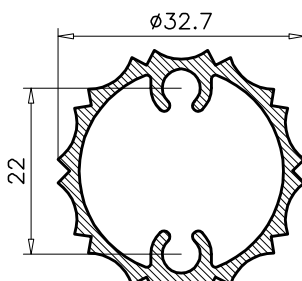

**1.366**  
 PESO TCO: 0.548  
 PERIMETRO: 0.24

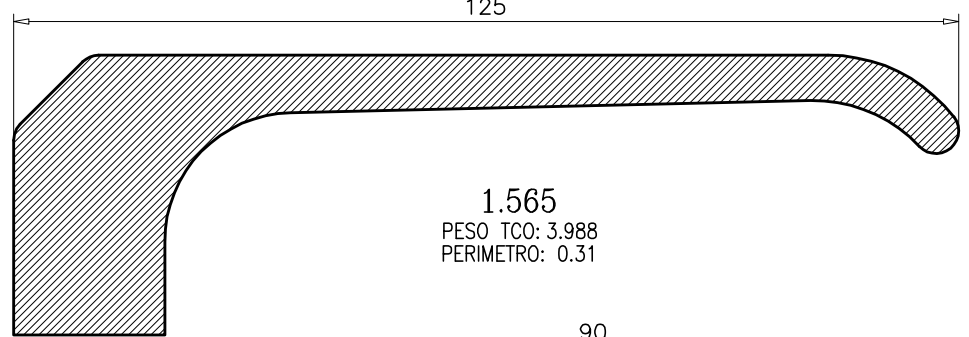

**1.565**  
 PESO TCO: 3.988  
 PERIMETRO: 0.31

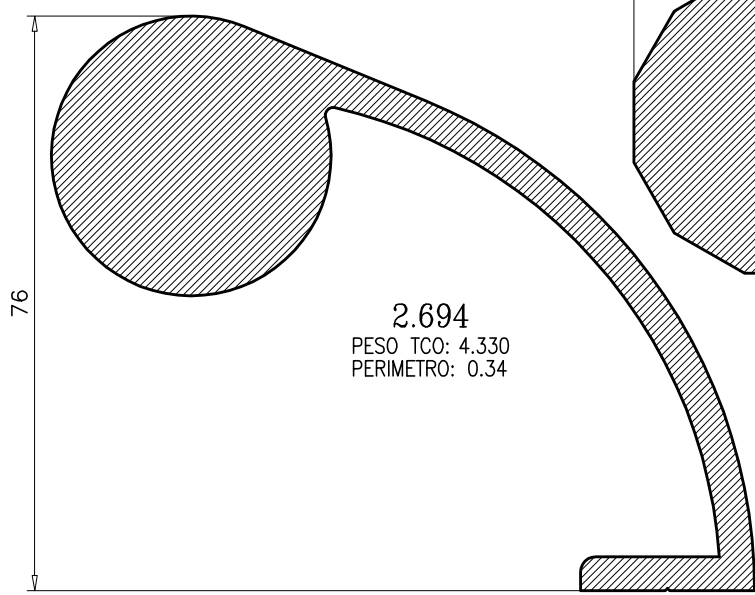

**2.694**  
 PESO TCO: 4.330  
 PERIMETRO: 0.34

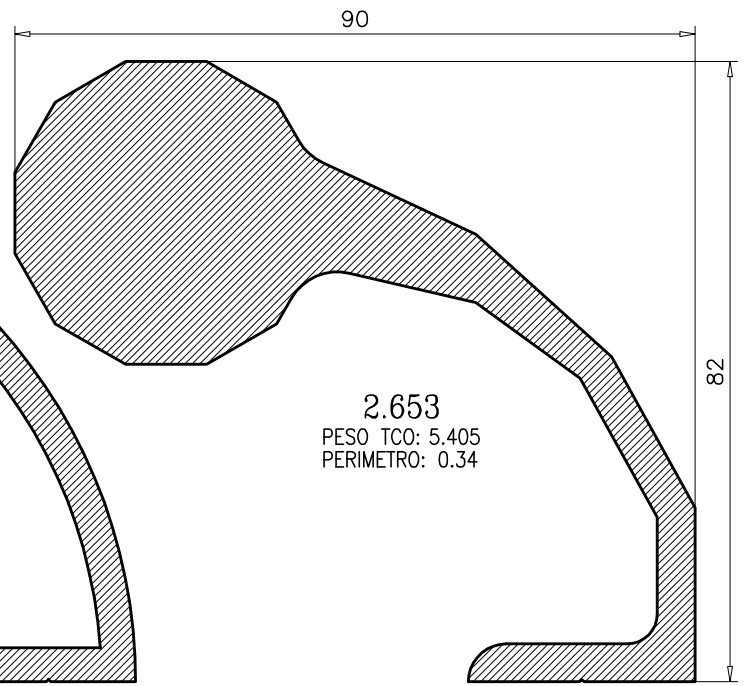

**2.653**  
 PESO TCO: 5.405  
 PERIMETRO: 0.34